

POSC09350D series

9V / 3.5A desktop type AC/DC adaptor



- Universal AC input / Full range
- ErP step II / CEC level VI compliance
- No load power consumption $P < 0.075W$
- Protections: Overload / Short circuit / Over Voltage

ELECTRICAL SPECIFICATION



MODEL POSC09350D-C8 / POSC09350D-C14

OUTPUT

Rated Voltage	9V
Rated Current	3.5A
Current Range	0 ÷ 3.5A
Rated Power	31.5W
Line Regulation	± 5%
Load Regulation	± 5%
Tolerance	± 8%
Ripple & Noise (max.)	200mV _{P-P}
Setup, Rise Time	100ms / Input 100-264Vac /load 10% to 90%
Hold up Time (typ.)	10ms / 230VAC at full load

INPUT

Voltage Range	90 ÷ 264VAC
Frequency Range	47 ÷ 63Hz
Efficiency (typ.)	87.08%
AC Current (typ.)	1.2A / 230VAC
No load Power Consumption (max.)	<1W

PROTECTIONS

Overload	Range: 4.2A- 7A Type: hiccup mode, auto-recovery.
Short Circuit	Type: hiccup mode, auto-recovery.
Over Voltage	Type: auto-recovery.
Over Temperature	140°C±10°C(detect on main control IC)

POSC09350D series

9V / 3.5A desktop type AC/DC adaptor



WORKING ENVIRONMENT

Working Temperature	-5°C ÷ 40°C
Working Humidity	5 ÷ 90% RH non-condensing
Storage Temperature and Humidity	-20°C ÷ 85°C, 5 ÷ 90% RH non-condensing

SAFETY and EMC REGULATIONS

Safety Standards	Compliance to EN 60950-1
Withstand Voltage	IN/OUT: 3.6kVAC
Isolation Resistance	IN/OUT: 100MΩ/500VDC/25°C/70%
EMC Emission	Compliance to EN55032
EMC Immunity	Compliance to EN61000-4-2, -3, -4, -5
Harmonic Current	Compliance to EN61000-3-3; EN61000-3-2

OTHERS

DC wire and plug	Wire: 18AWG*2C, length = 1200mm	Plug: 2.1/5.5, positive inside
Dimensions	115.0 x 49.5 x 31.0mm (L x W x H)	

MECHANICAL SPECIFICATION

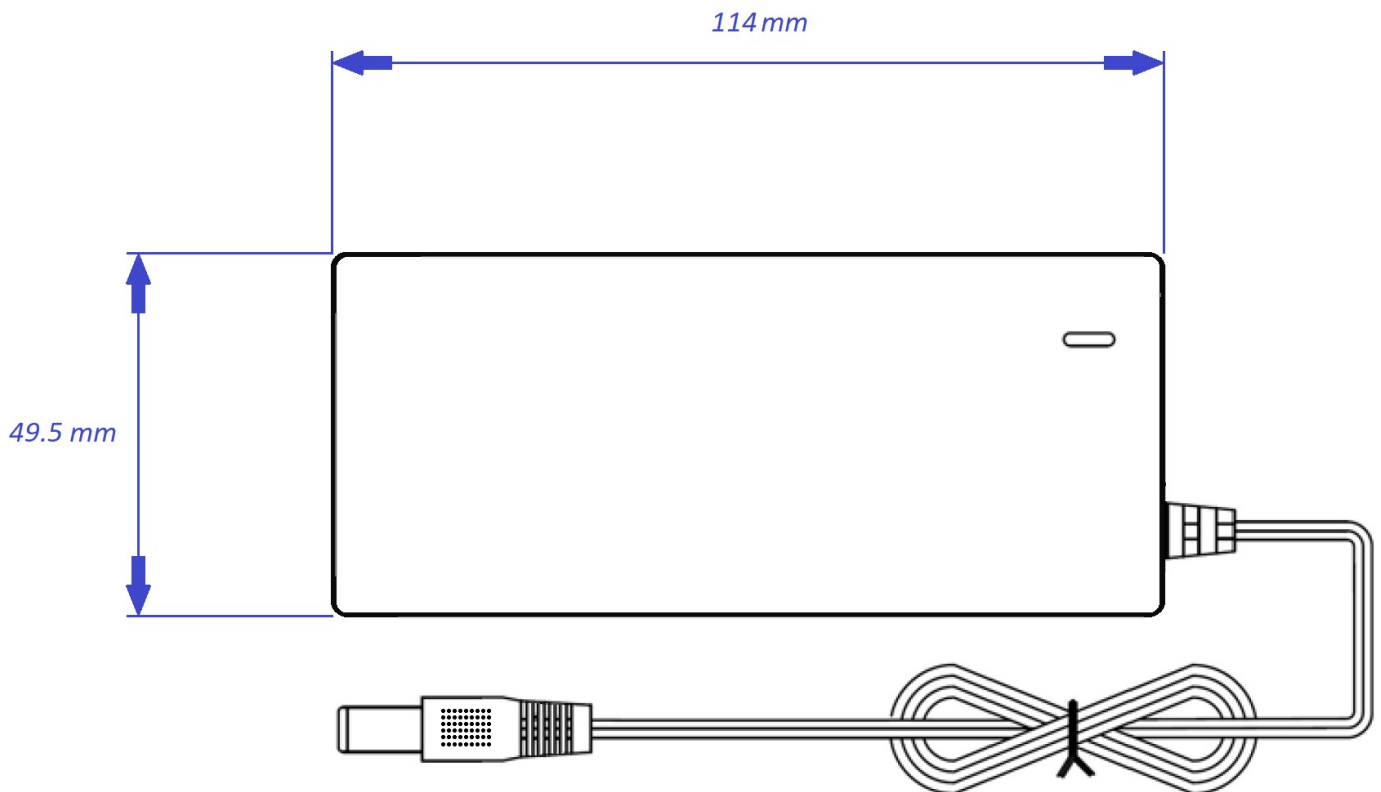

POSC09350D series

9V / 3.5A desktop type AC/DC adaptor



MECHANICAL SPECIFICATION: DC wire and plug

POSC09350D-C14

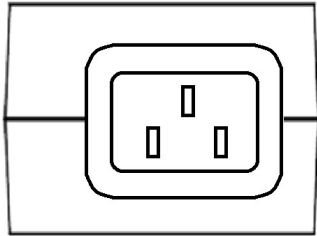

POSC09350D-C8

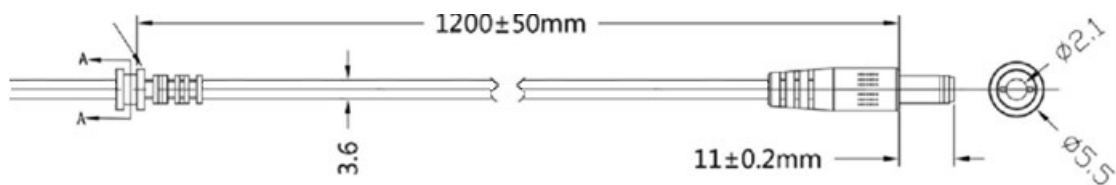
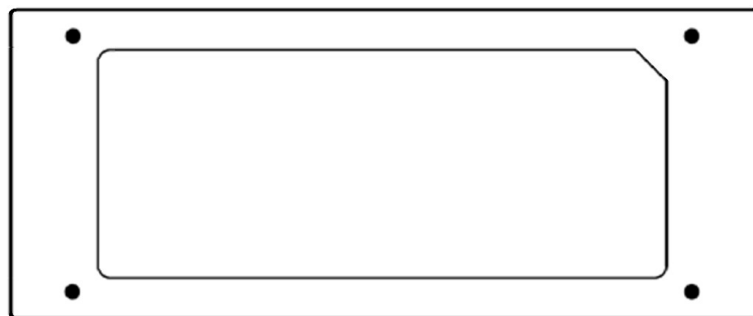
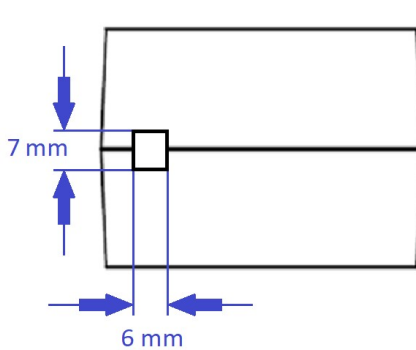
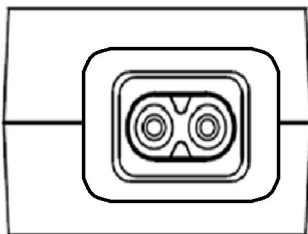

1. All parameters NOT specially mentioned are measured at 230VAC input, rated load and 25°C of ambient temperature.
2. Ripple & noise are measured at 20MHz of bandwidth by using a 12" twisted pair-wire terminated with a 0.1µF i 47µF parallel capacitor.
3. Tolerance includes set up tolerance, line regulation and load regulation.
4. Setup and rise time is measured from 0 to 90% rated output voltage.
5. Power supply is considered as component not indented to apply by end-user. Power supply meets safety and EMC standards however the final equipment with power supply must be re-quality to comply with EMC Directives.